

Medical Cart Computer

Venus-244

24" Dual Hot Swappable Battery Medical Cart Computer

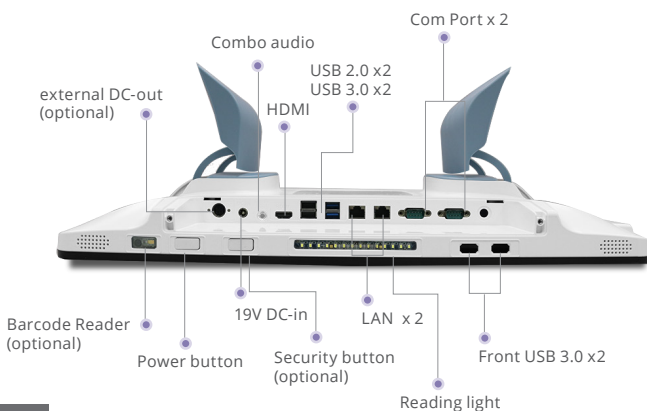
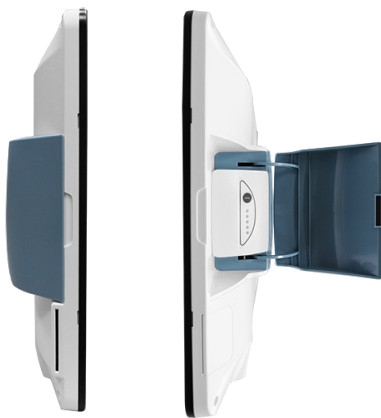

Features

- Intel 11th gen Tigerlake, fan less implementation
- Windows 11 and IGEL Compliant
- Dual Hot Swappable Batteries
- Easy cleanable and anti-bacterial
- Internal Imprivata compliant RFID reader (optional)
- WiFi 6 (optional)
- Compliant with all Venus batteries
- Remotely Manageable by central IT departments

Specifications

MAIN SPECIFICATIONS

Processor	Intel® 11th generation Core i7 1165G7 / i5 1135G7
System Memory	DDR4 up to 64GB
OS Support	Microsoft® Windows 11 Microsoft® Windows 10 (64bit) Ubuntu 20.04 LTS IGEL (thin client solution)
Storage	m.2 SSD up to 1TB
Wireless Communication	802.11 a/b/g/n/ac/ax (optional) WiFi 6E + Bluetooth 5.3 (optional)
Touch	PCT (optional)
Speaker	3W x 2
Trusted Platform Module	TPM 2.0
Security	Smart Card Reader (optional), Imprivata RFID reader (optional), Barcode reader (optional)
Waterproof	Front IP65 ; rear IPX1

DISPLAY

Display Size	23.8"
Resolution	FHD 1920 x 1080
Max. Colors	16.7M
Contrast Ratio	3000:1
Luminance (cd/m2)	250

I/O

USB	Rear I/O : USB 3.0 x 2, USB 2.0 x 2 Front button I/O : USB 3.0 x 2
Video Out	HDMI 1.4 x 1
COM	COM port x 2
Audio	Combo audio port x 1
Ethernet	1.5kv isolated Gigabit LAN x 2
DC-in	19V DC-in x 1

MECHANICAL AND ENVIRONMENTAL

VESA	75/100 mm VESA mount
Operating Temperature	0°C ~ 35°C (32°F ~ 95°F)
Storage Temperature	-20°C ~ 60°C (-4°F ~ 140°F)
Storage Humidity	10%~95%@40°C, non-condensing
Dimension	560(L) x 78.4(W) x 373(H)
Package Size	730(L) x 240(W) x 550(H) mm
Gross Weight	11kg(24.3lbs)
Net Weight	7kg
Certifications	CE: EN 60601-1-2: 2015 + A1: 2021 (V4.1), EN 60601-1: 2007 + A1: 2013 + A2: 2021 (V3.2) EN 55032: 2015/A1: 2020 EN 55035: 2017/A11: 2020 (ITE) IEC62368-1: 2020 + A11: 2020 (ITE) FCC : Part 15B/ Part 18 UL: ANSI AAMI ES60601-1: 2005/A1: 2012/A2: 2021 (V3.2) cUL: CAN/CSA-C22.2 No. 60601-1:14 (IEC 60601-1: 2005+A1: 2012+A2: 2020, MOD) (V3.2) TELEC JAPAN TELECOM

ALL PRODUCT, PRODUCT SPECIFICATIONS AND DATA ARE SUBJECT TO CHANGE WITHOUT NOTICE TO IMPROVE RELIABILITY, FUNCTION OR DESIGN OR OTHERWISE.

24" Dual Hot Swappable Battery Medical Cart Computer

Dimension / Unit: mm

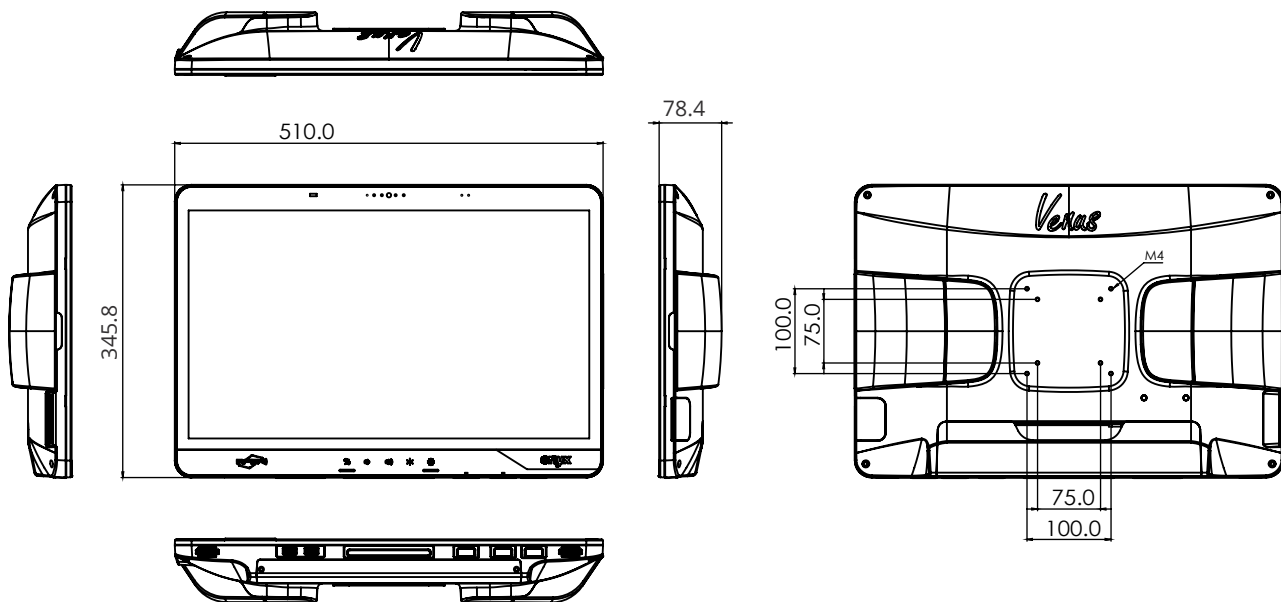

Ordering Information

- VENUS-244-P35-A1-0000
Cart Computer.i5 1135G7.24".Fanless.PCT.TPM
- VENUS-244-G75-A1-0000
Cart Computer.7505.24".Fanless.TPM

Optional Accessories

- 125530120B
19V medical adapter
- DDR4-08G-04
DDR4 3200 8GB RAM
- SSD-256GB-003
(AOH)(TF)M.2 2242 SSD.TLC.256GB
- 9789BAXL14
2 XL Battery Kit(long).Li-ion 3S3P.10.95V.Venus/UPower.
volume package
- OPM-C17W-A1
Wifi 6 (intel ax200) for Venus-22x
- OPM-C15W-A8
WLAN Kit 802.11 a/b/g/n/d . BT 5 . dual band antenna.
Intel AC9260
- OPM-T035-A1
Smart card reader
- OPM-S02R-A3
RFID (imprivata compatible)
- OPM-V02C-A1
Hello camera
- OPM-S09R-A1
Barcode reader
- OPM-T036-A1
Customize physical button
- OPM-T037-A1
Alarm LED